

Ethernet to Token Ring Bridge

Quick Installation Guide



Version 2.3 March 2004

COPYRIGHT

Copyright 1998-2004 © Ringdale UK Ltd. All rights reserved. No part of this publication may be reproduced, transmitted, transcribed, stored in a retrieval system, or translated into any language or any computer language, in any form or by any third party, without prior permission of Ringdale UK Limited.

DISCLAIMER

Ringdale UK Ltd. reserves the right to revise this publication and to make changes from time to time to the contents hereof without obligation to notify any person or organisation of such revision or changes. Ringdale UK Ltd. has endeavoured to ensure that the information in this publication is correct, but will not accept liability for any error or omission.

TRADEMARKS

All trademarks are hereby acknowledged.

Part No. 62-13010010

Introduction

The Ethernet to Token Ring Bridge enables a device with an Ethernet output to be connected to a Token Ring network.

Because this product doesn't require any user setup or configuration procedure, the installation is simple, and once installed the bridge operates automatically.

This guide details the simple steps required to get the bridge functioning and includes a troubleshooting section for possible problems that might be encountered, enabling an Ethernet based product to gain the full benefit of your Token Ring Network.

Installation

Powering the Bridge

Connect the power cable to the **Power Supply** socket on the **Ethernet** panel of the bridge (see diagram overleaf). Connect the other end of the power cable to the mains electricity supply.

The **Power** LED lights up and the bridge is ready for operation.

Note: If there is a delay in connecting the bridge to the Token Ring network after power-up, it may be necessary to restart the bridge in order to make the network link good.

Connectors and LEDs

Ethernet Panel

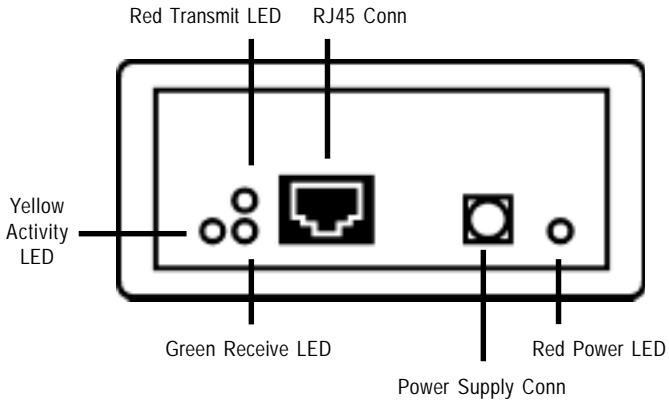

Token Ring Panel

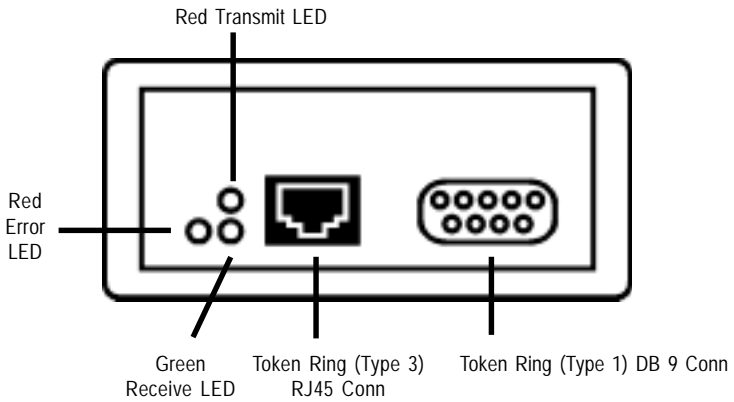

Connecting the Bridge

Ethernet Panel

Insert the **RJ-45 10baseT** cable from the required Ethernet device into the **RJ-45** port on the Ethernet panel.

The green **Receive** LED will blink when the bridge receives data from the Ethernet device.

The red **Transmit** LED will blink when the bridge transmits data to the Ethernet device.

The yellow **Activity** LED will blink whenever data is passed to and from the Ethernet device and the bridge.

Token Ring Panel

Insert either a **Type 3** cable with a **RJ-45** connector or a **Type 1** cable with a **9 way DB** connector from the Token Ring network (normally a MAU) into the **RJ-45** or **DB 9** port respectively on the Token Ring panel. The bridge will *autosense* which Token Ring connector is being used.

The red **Error** LED will light when there is an error on the Token Ring network.

The green **Receive** LED will blink when the bridge receives data from the network.

The red **Transmit** LED will blink when the bridge transmits data from the Ethernet device to the Token Ring network.

The bridge is now fully operational and its performance can be monitored using the LEDs.

Typical Setup for the Ethernet to Token Ring Bridge

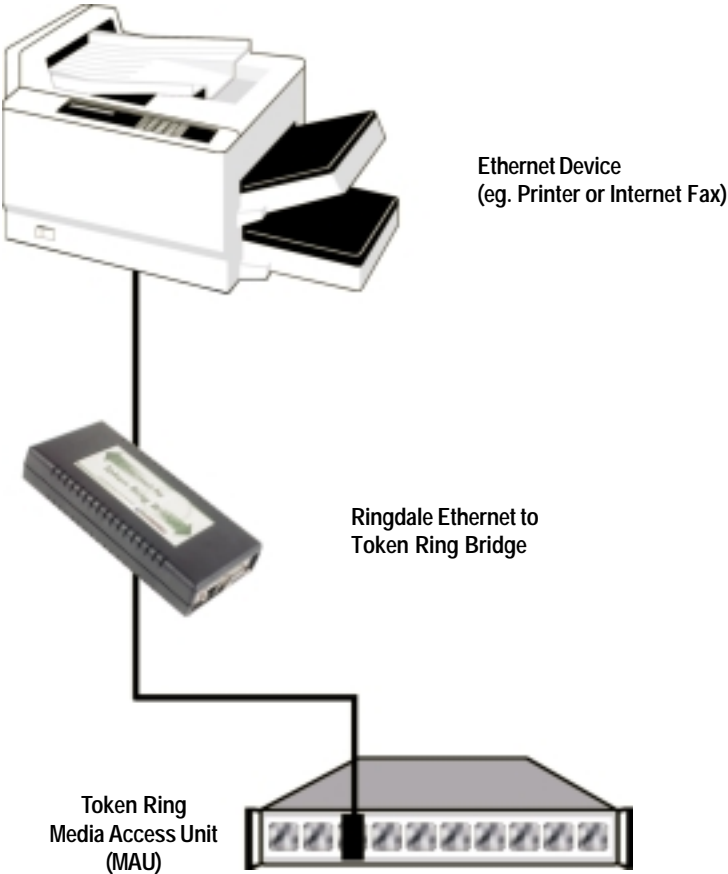

Setting the Token Ring Speed

The bridge will *autosense* the Token Ring speed of 4MHz or 16MHz. This is the default setting.

Should it be necessary, the bridge can be set to either 4MHz or 16MHz only.

To do this, hold the bridge at the sides and squeeze hard, pulling the top and bottom halves apart. The Token Ring speed pins are located on the circuit board behind the power supply socket and are easily identified by a red jumper. The layout is shown in the diagram below.

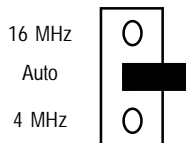

The red jumper will be over the **Auto** pin only, enabling the bridge to select 16MHz or 4MHz as required. To set one speed only, remove the jumper and replace it over the **Auto** pin *and* the pin of the speed you wish to set, as shown in the diagrams below.



After the setting has been selected, close the casing again and the bridge will operate only to the speed selected.

Upgrading Firmware

To perform a version check or download a new release of firmware to the bridge it is necessary to connect the **Ethernet** port to an isolated network with one PC attached. The PC must have its IP address set to **11.22.33.44**.

Important: the bridge must be disconnected from the **Token Ring** network and re-powered for this procedure.

Version Check

Open a **Telnet** session to 11.22.33.44 using port 9100. Information and the firmware version number will be displayed.

Firmware Upgrade

The Telnet port 9100 protocol can be used to upgrade the firmware should this become necessary.

To obtain a download utility and the latest firmware version contact Ringdale technical support (contact details can be found on the back cover of the manual).

Important Information

The device is designed to operate in a typical office environment. Choose a site that is:

Well ventilated and away from sources of heat including direct sunlight.

Away from sources of vibration or physical shock.

Isolated from strong electromagnetic fields produced by electrical devices.

Provided with a properly grounded wall outlet.

Do not attempt to modify or use the supplied AC power cord if it is not the exact type required.

Ensure that the system is disconnected from its power source and from all telecommunications links, networks, or modem lines whenever the chassis cover is to be removed. Do not operate the system with the cover removed.

Do not use in a damp environment

Troubleshooting

If the Token Ring Bridge is not connecting to the network please follow the Trouble shooting Guide Below:

Symptom	Resolution
If there has been a delay in connecting the bridge to the Token Ring device	Power off Bridge and power on again
The Red <i>Error</i> LED is always on	Check that the cable works and that the port on the MAU works
	Check the jumper settings are correct inside the bridge, consult page 7 for details
	Unplug any devices from the Ethernet side and power cycle the bridge, When the <i>Error</i> LED goes out, connect the Ethernet device
I cannot ping the Ethernet device I have connected to	Check the <i>Error</i> LED is not lit, If it is follow the steps above
	Check the Amber LED on the Ethernet side is lit. If not, ensure the Ethernet device is powered on and that the cable is working correctly
	Check that the bridge is only connected to one Ethernet device
	Ensure that there is a fixed IP address assigned to the Ethernet device and that the correct address is being pinged
	Check the IP address on the Ethernet unit has not changed. If it has, power down the Ethernet device, power down the bridge. Reboot the bridge and then reboot the Ethernet device only after the bridge has connected to the Token Ring network

<i>Symptom</i>	<i>Resolution</i>
	Check that the Ethernet device transmits a packet after power on by ensuring that the Green LED on the Ethernet side of the bridge flashes periodically. If it does not, set the Ethernet device to a mode that issues unsolicited packets, such as enabling DHCP, WINS or SAP modes
The bridge is connected correctly but data transfer is slow / sometimes I lose data	Check that the Ethernet device the bridge is connected to supports IP fragmentation. If not, contact the Ethernet device vendor or set the Maximum Packet Transmit size on the Token Ring devices to 1400 bytes.
	Check that the packets being sent are TCP/IP only.

Technical Specification

Operating Voltage:	5 volts DC -5/+10%
Power Consumption:	<300mA
Processor:	High Performance CPU - AB68033
ROM:	Flash EPROM: 256K X 8
RAM:	128K X 8 static RAM
Token Ring Connectors	Type 1 DB9, Type 3 RJ-45
Ethernet Connector	RJ-45 type
Communication Speed	4/16 Mbit/s (Token Ring) 10 Mbit's (Ethernet)
Operating Environment	Temperature: 10°C to 35°C Relative Humidity: 15% to 70%

Note: specifications are subject to change without notice.

**Ringdale Ltd
26 Victoria Way
Burgess Hill
West Sussex
RH15 9NF
United Kingdom**

**Freephone: 0800 214503
Tel: +44 (0) 1444 871349
Fax: +44 (0) 1444 870228**

**Ringdale GmbH
Cochemer Straße 12-14
D-68309 Mannheim
Germany**

**Freephone: 0800 - 8251880
Tel: +49 (0) 621 7186-0
Fax: +49 (0) 621 7186-20**

**Ringdale Inc
101 Halmar Cove
Georgetown, Texas 78628
USA**

**Freephone: 888 288 9080
Tel: +1 512 288 9080
Fax: +1 512 288 7210**

Website: <http://www.ringdale.com>